

- Multimedia?
- Format/types
- Structure
- Animations
- 3D models
- Simulation
- Reuse
- Color
- Configuration management
- Source and content across the enterprise
- A solution for 3D models
- Questions

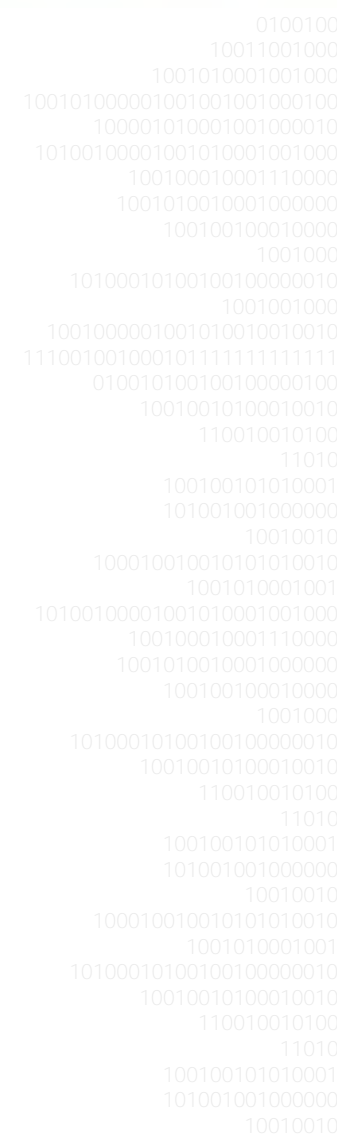

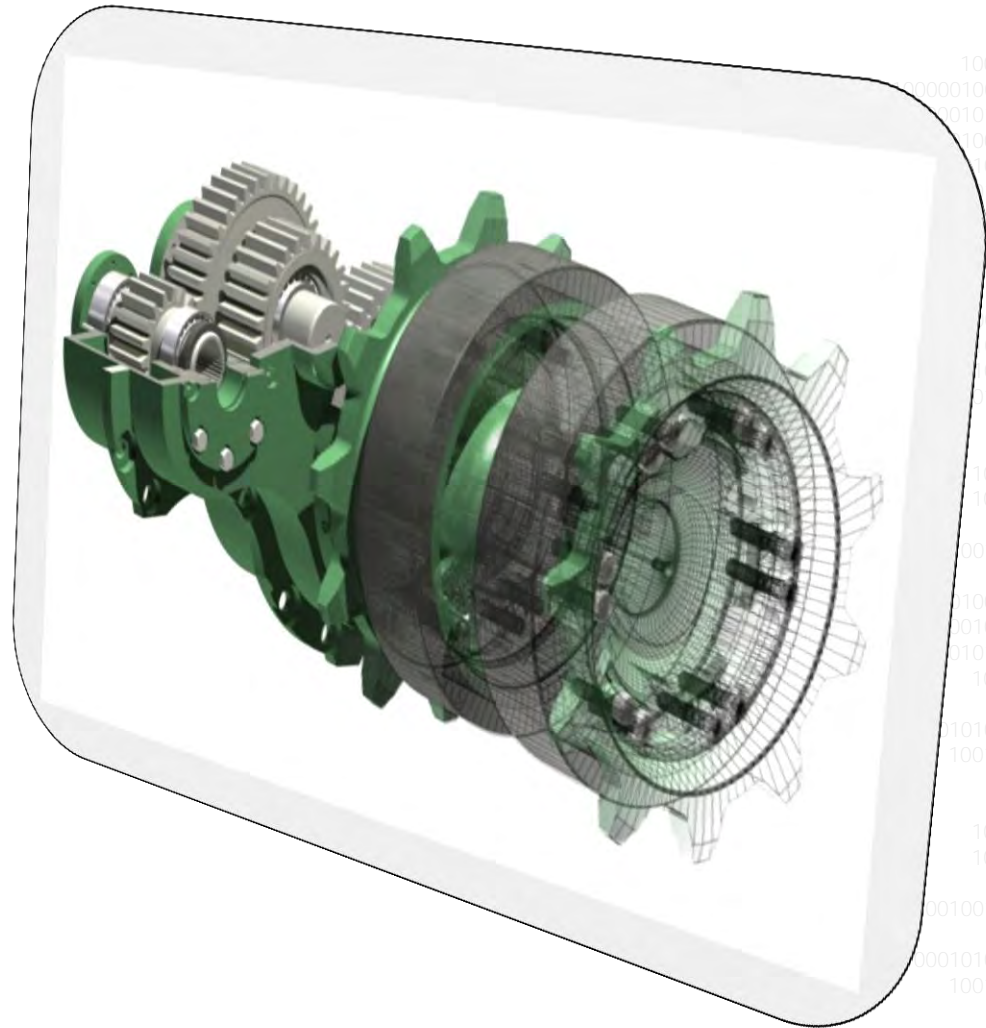
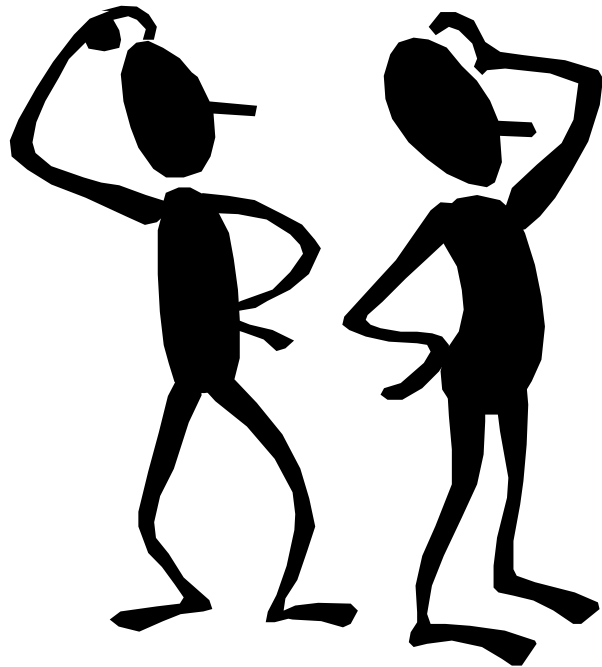

0100100
100110010
100101000100100
00001001001000100
01010001001000010
1001010001001000
100010001110000
10010001000000
0100100010000
1001000
0100100000010
1001001000
1010010010010
01111111111111
00100100000100
010010100010010
110010010100
11010
00100101010001
101001001000000
10010010
0010010101010010
1001010001001
1001010001001000
0100010001110000
1010010001000000
100100100010000
1001000
01010010010000010
10010010100010010
110010010100
11010
100100101010001
101001001000000
10010010
00100100101010010
1001010001001
0001010010010000010
10010010100010010
110010010100
11010
100100101010001
101001001000000
10010010
0001010010010000010
10010010100010010
110010010100
11010
100100101010001
101001001000000
10010010
10010010

Audio



10 encodings providing 19 file types

Video



17 encodings providing 39 file types

3D Models



17 encodings providing 33 file types

Miscellaneous



7 file types

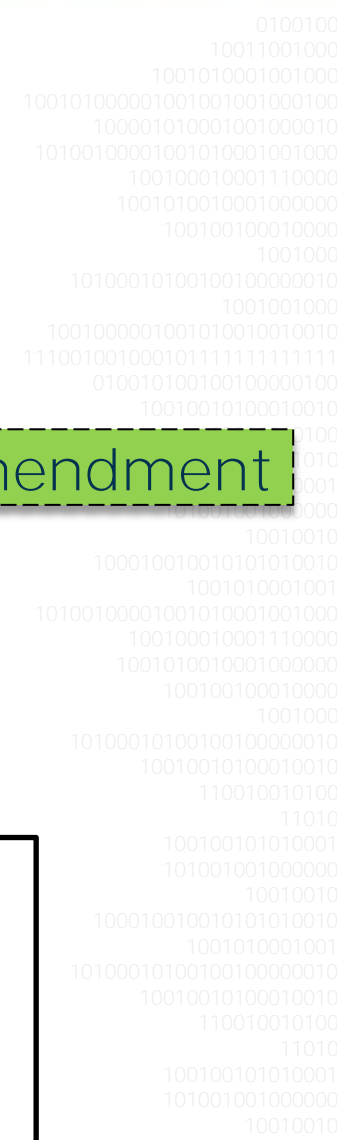
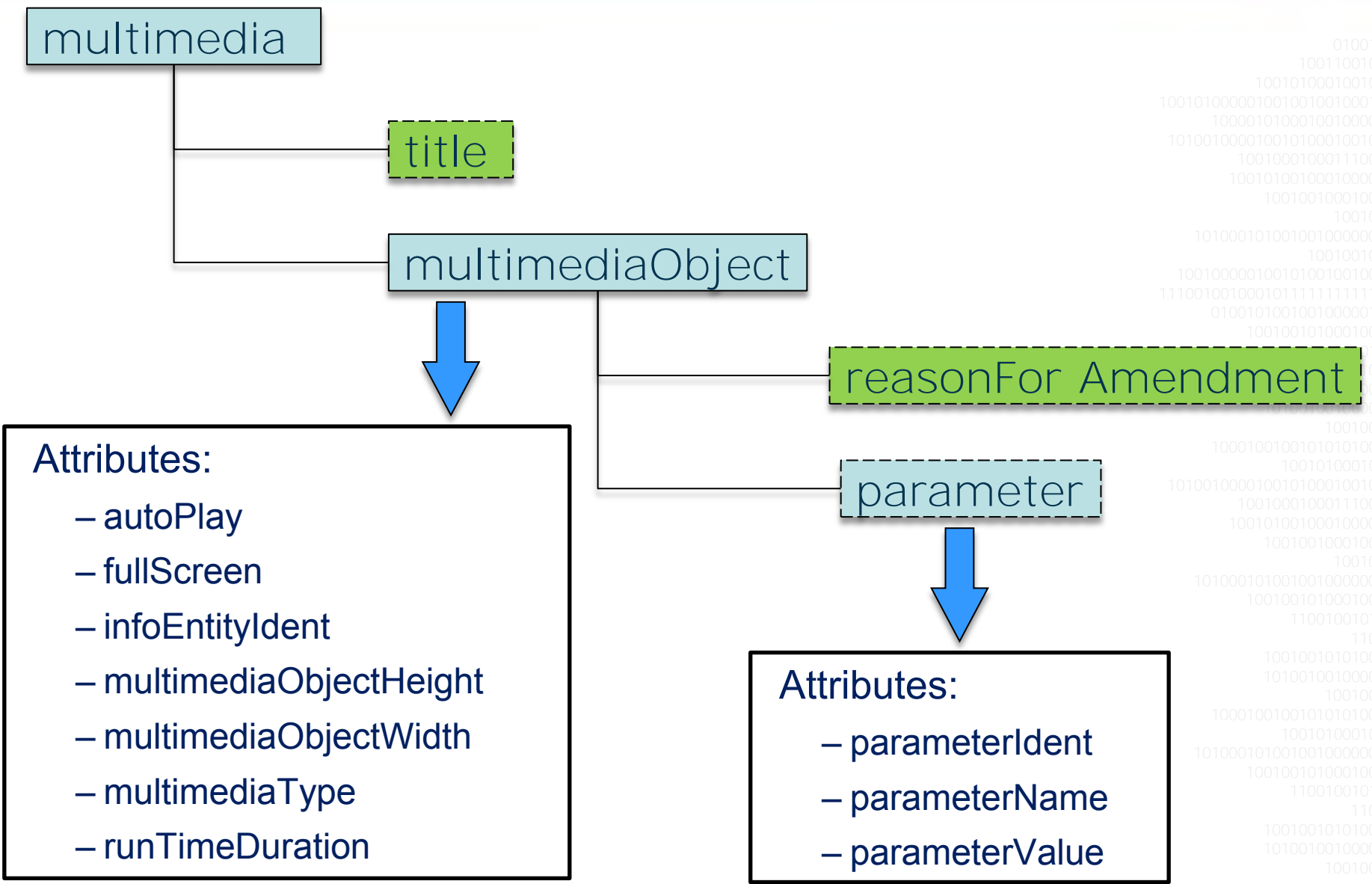

2D Graphic Animation

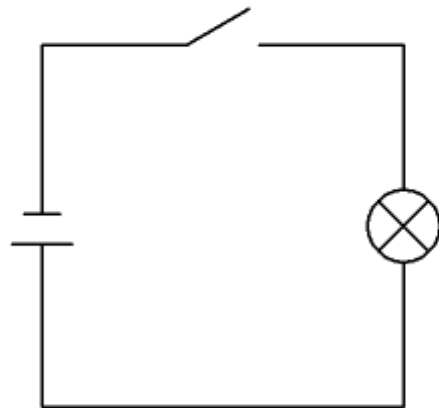

0100100
100110010
100101000100100
001001001000100
010001001000010
01010001001000
00010001110000
10010001000000
00100100010000
1001000
00100100000010
1001001000
01010010010010
01111111111111
00100100000100
10010100010010
110010010100
11010
00100101010001
01001001000000
10010010
10010101010010
1001010001001
01010001001000
00010001110000
10010001000000
00100100010000
1001000
00100100000010
10010100010010
110010010100
11010
00100101010001
01001001000000
10010010
10010101010010
1001010001001
00100100000010
010010100010010
110010010100
11010
100100101010001
10100100100000
10010010



Animated Disassembly Procedure

0100100
100110010
100101000100100
001001001000100
010001001000010
01010001001000
00010001110000
10010001000000
00100100010000
1001000
00100100000010
1001001000
01010010010010
01111111111111
00100100000100
10010100010010
110010010100
11010
00100101010001
01001001000000
10010010
10010101010010
1001010001001
01010001001000
00010001110000
10010001000000
00100100010000
1001000
00100100000010
10010100010010
110010010100
11010
00100101010001
01001001000000
10010010
10010101010010
1001010001001
00100100000010
010010100010010
110010010100
11010
100100101010001
101001001000000
10010010



Animated Assembly Procedure

0100100
100110010
1001010000100100
0010010010000100
0100010010000010
010100001001000
000100001110000
10010001000000
00100100000000
1001000
001001000000010
1001001000
01010010010010
011111111111111
001001000000100
10010100010010
110010010100
11010
001001010100001
01001001000000
10010010
10010101010010
10010100001001
010100001001000
000100001110000
100100001000000
001001000010000
1001000
001001000000010
100101000010010
110010010100
11010
001001010100001
01001001000000
10010010
10010101010010
10010100001001
001001000000010
0100101000010010
110010010100
11010
1001001010100001
101001001000000
10010010

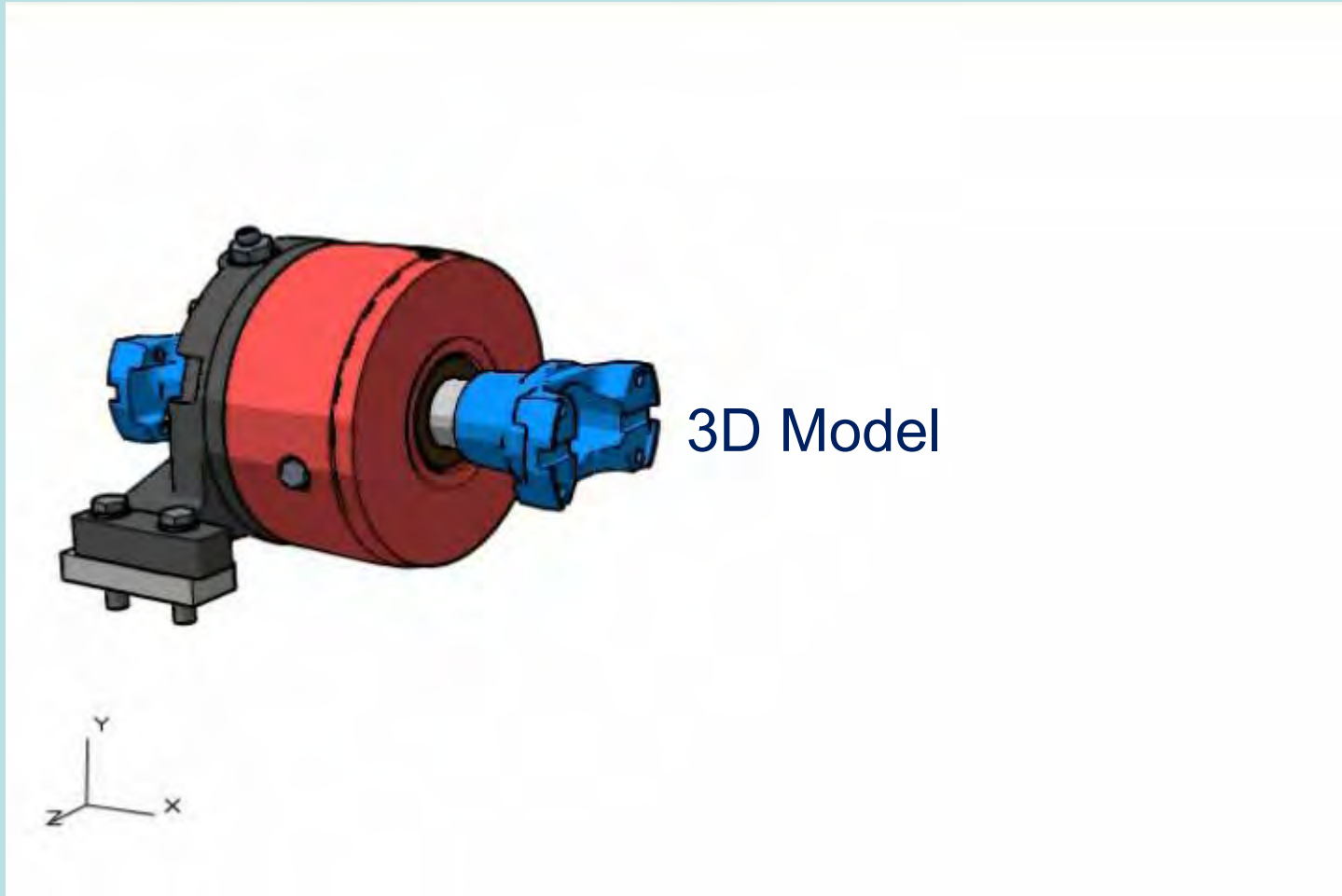

0100100
100110010
100101000100100
001001001000100
010001001000010
01010001001000
00010001110000
10010001000000
00100100010000
1001000
00100100000010
1001001000
01010010010010
01111111111111
00100100000100
10010100010010
110010010100
11010
00100101010001
01001001000000
10010010
10010101010010
1001010001001
01010001001000
00010001110000
10010001000000
00100100010000
1001000
00100100000010
10010100010010
110010010100
11010
00100101010001
01001001000000
10010010
10010101010010
1001010001001
00100100000010
010010100010010
110010010100
11010
100100101010001
101001001000000
10010010

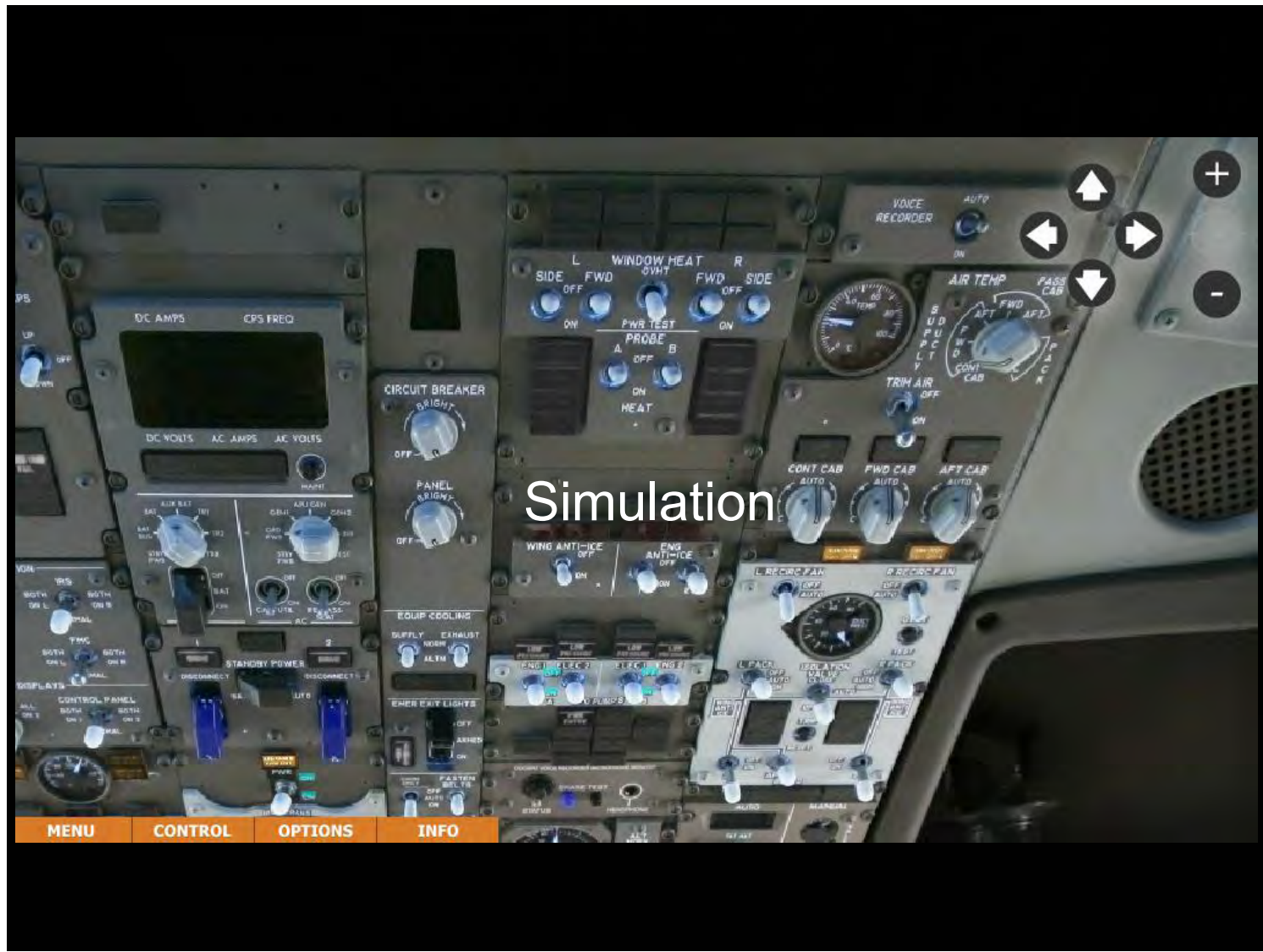

0100100
0110010
1001010
0100100
01010001
000010
01001010
001000
00100010
110000
01010010
000000
100100
001000
01010010
000010
1100100
000100
10010010
0000100
110
010100
11010
100100
010001
101001
000000
010100
010010
1001
001001
01001010
001000
00100010
110000
01010010
000000
100100
001000
01010010
001000
110
010100
11010
100100
010001
101001
000000
01010010
010010
1001
001001
01010010
000010
10010010
0010010
11
00010100
11010
100100
0101010001
001001000000
10010010

E-Learning Demonstration

Pivot Pin Bush: Lubrication, fitting, removal & installation

Training

- Replay Intro
- Contents
- Overview
- Disassembly
- Clean & Inspect
- Assembly
- Equipment & Materials
- Warnings & Cautions
- NDT

0100100
100110010
101000100100
1001001000100
0001001000010
1010001001000
0010001110000
0010001000000
0100100010000
1001000
0100100000010
1001001000
1010010010010
1111111111111
0100100000100
0010100010010
110010010100
11010
0100101010001
1001001000000
10010010
0010101010010
1001010001001
1010001001000
0010001110000
0010001000000
0100100010000
1001000
0100100000010
0010100010010
110010010100
11010
0100101010001
1001001000000
10010010
0010101010010
1001010001001
0100100000010
0010100010010
110010010100
11010
100100101010001
101001001000000
10010010
0010101010010
1001010001001
0100100000010
0010100010010
110010010100
11010

2D Color – 3D Color

- Orange - warnings and danger areas, associated system colors: Pneumatics, Electrical and Automation
- Red
- Yellow
- Blue
- Light Yellow - reference items, structure, locator views and peripheral information
- Green
- Light Blue
- Orange
- Light Grey
- Light Blue
- Amber - detail items, attaching parts and removal / installation procedure.

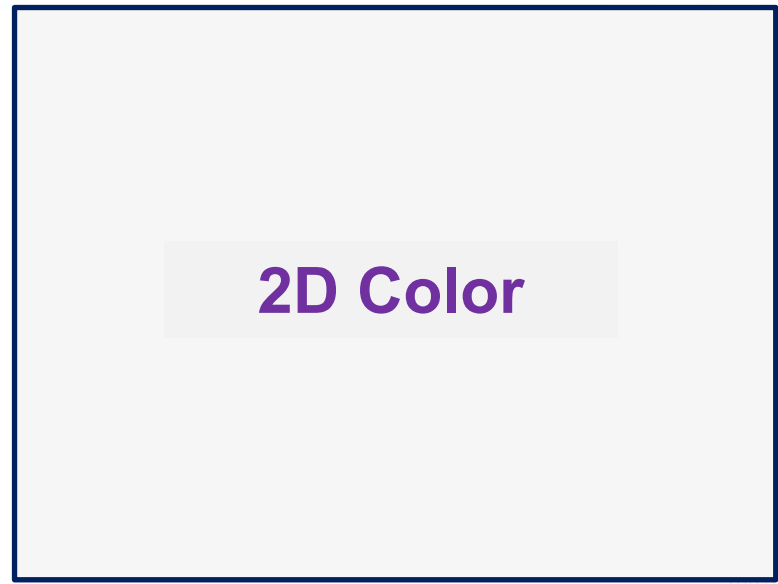

100
010
001
000
100
010
000
000
000
010
000
010
111
100
100
010
001
000
010
001
000
000
000
000
010
010
100
010
001
000
000
000
000
010
010
100
010
001
000
010
010
100
010
001
000
010



Information Control Number

Used to uniquely identify a non XML entity

- ◆ Image
- ◆ Sound
- ◆ Movie
- ◆ 3D Model

Two types, they are either:

- ◆ A company/organization code - CAGE code based
- ◆ a project code - model identification code based

Model identification code based can be used to associate multimedia with the SNS

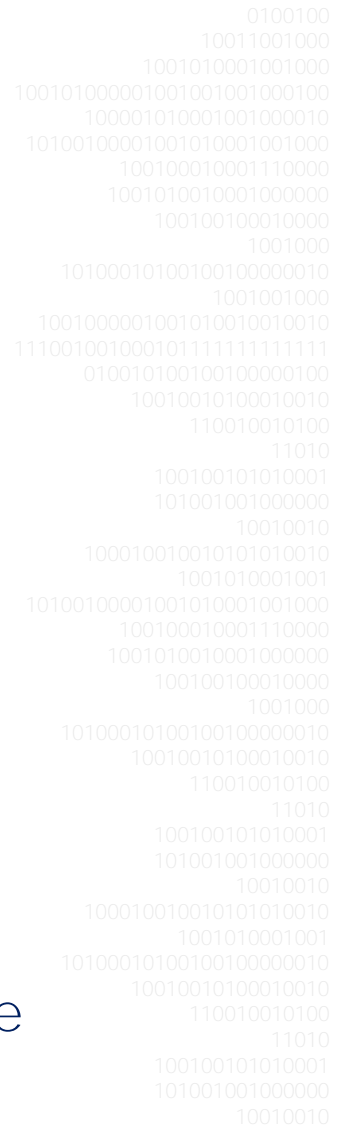

Information Control Number

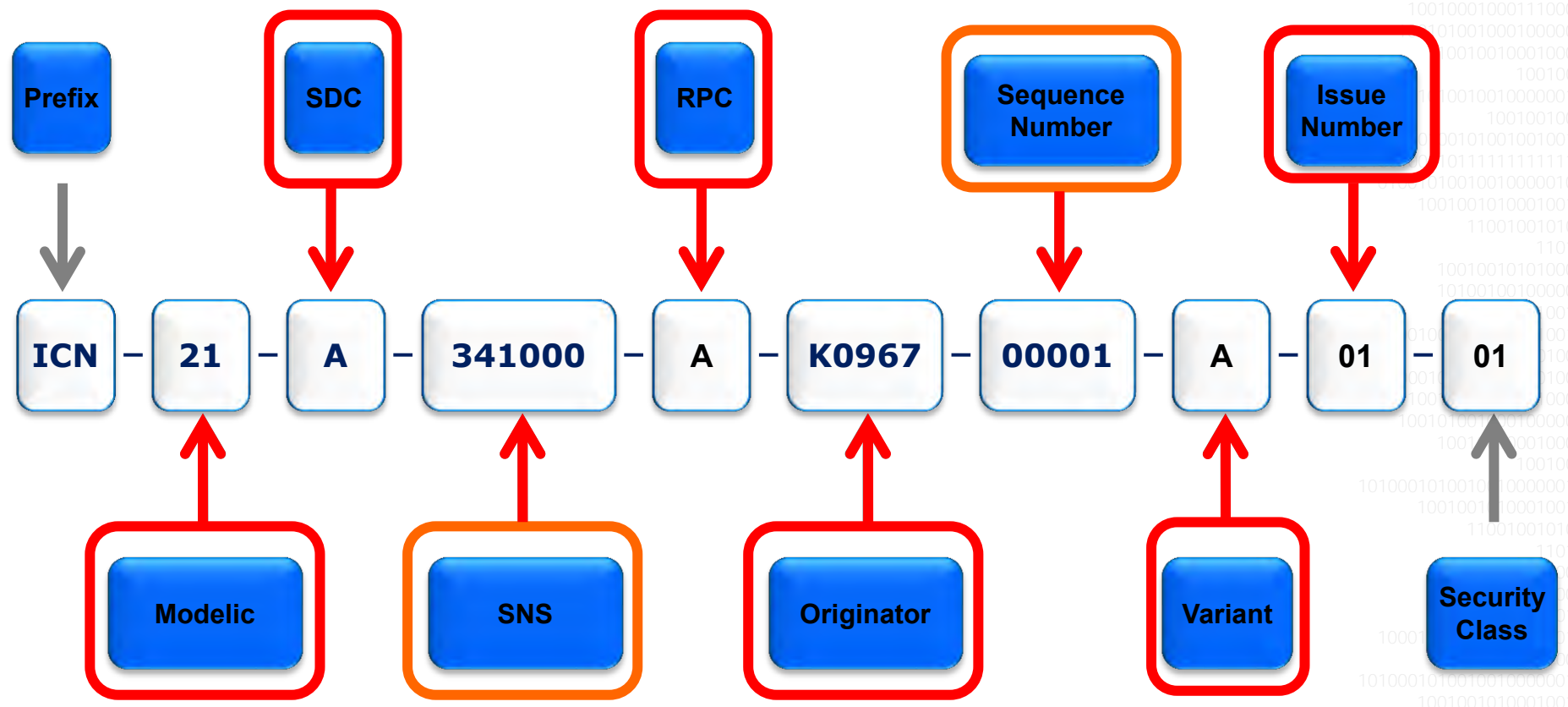

Multimedia in S1000D – The Future?

Multimedia – Configuration management

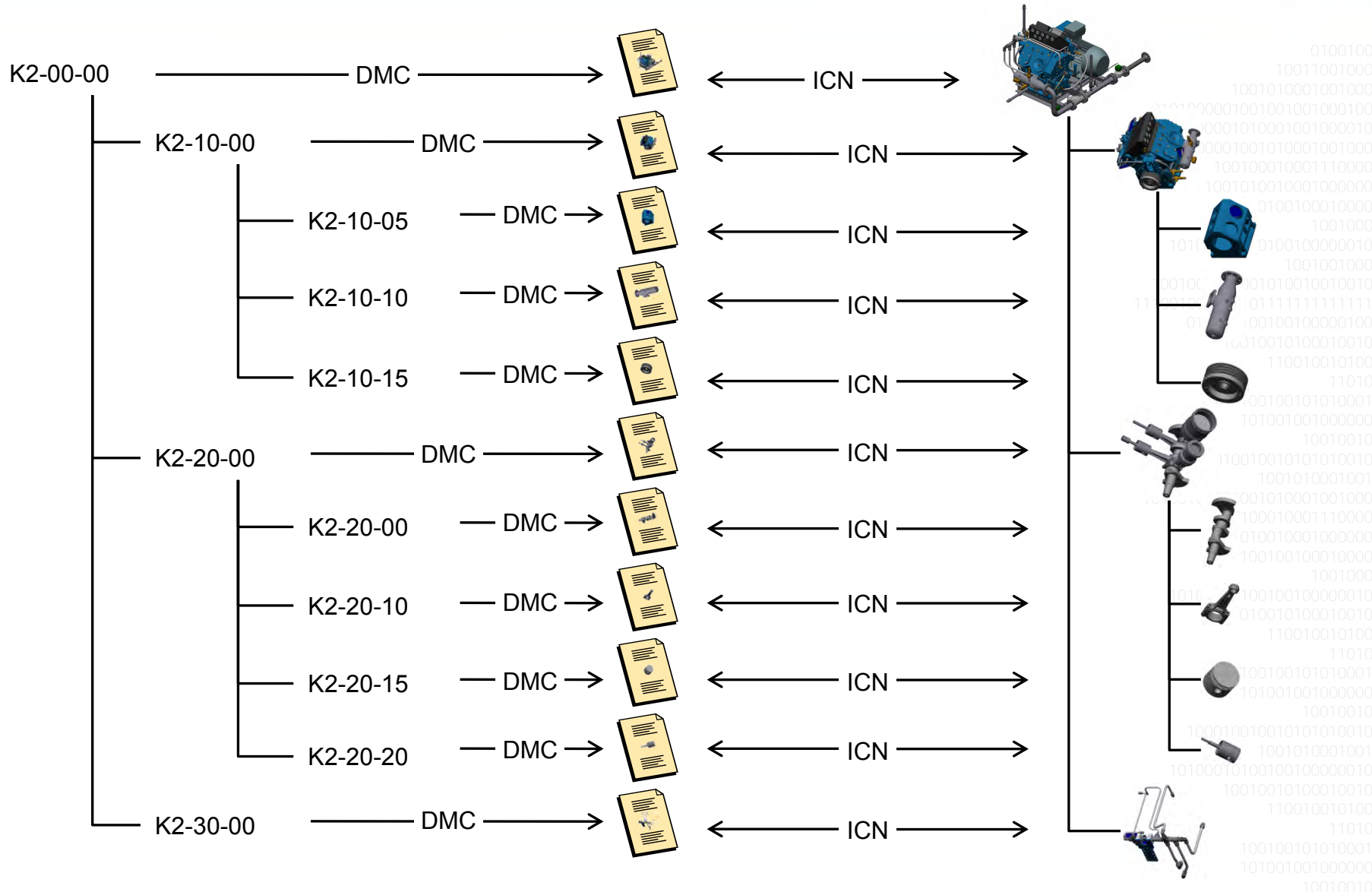

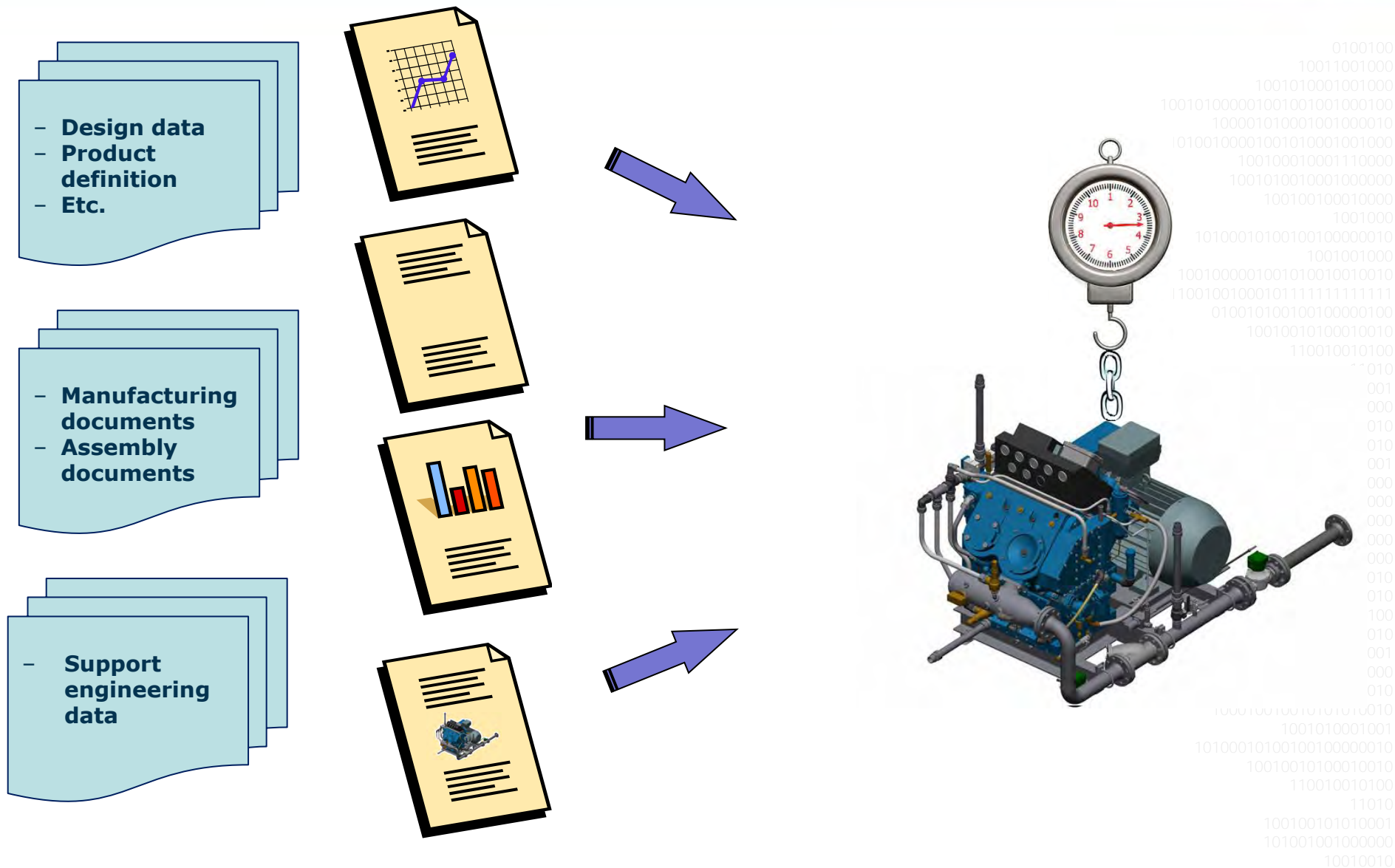

Multimedia in S1000D – The Future?

Multimedia – 3D model use and reuse

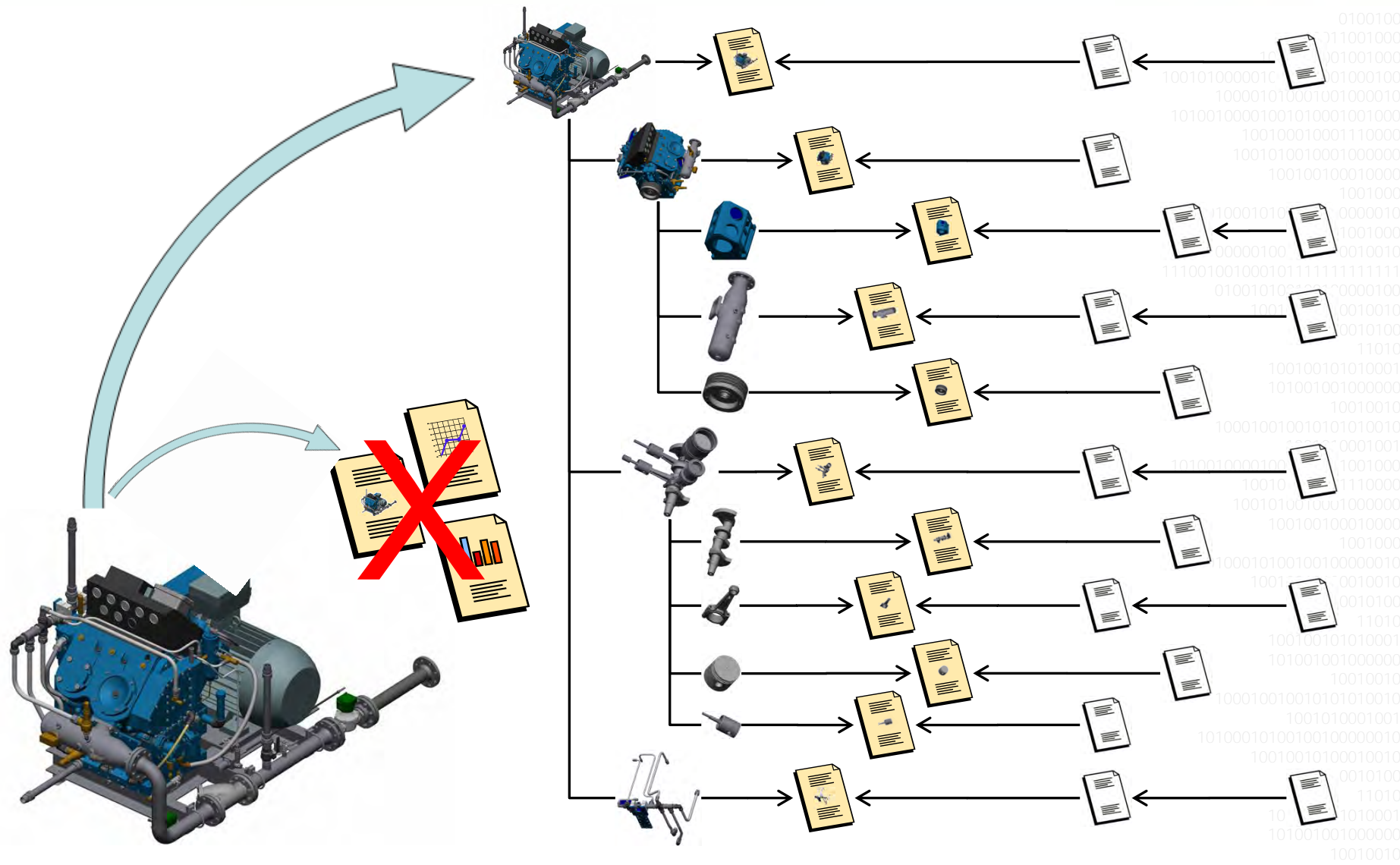

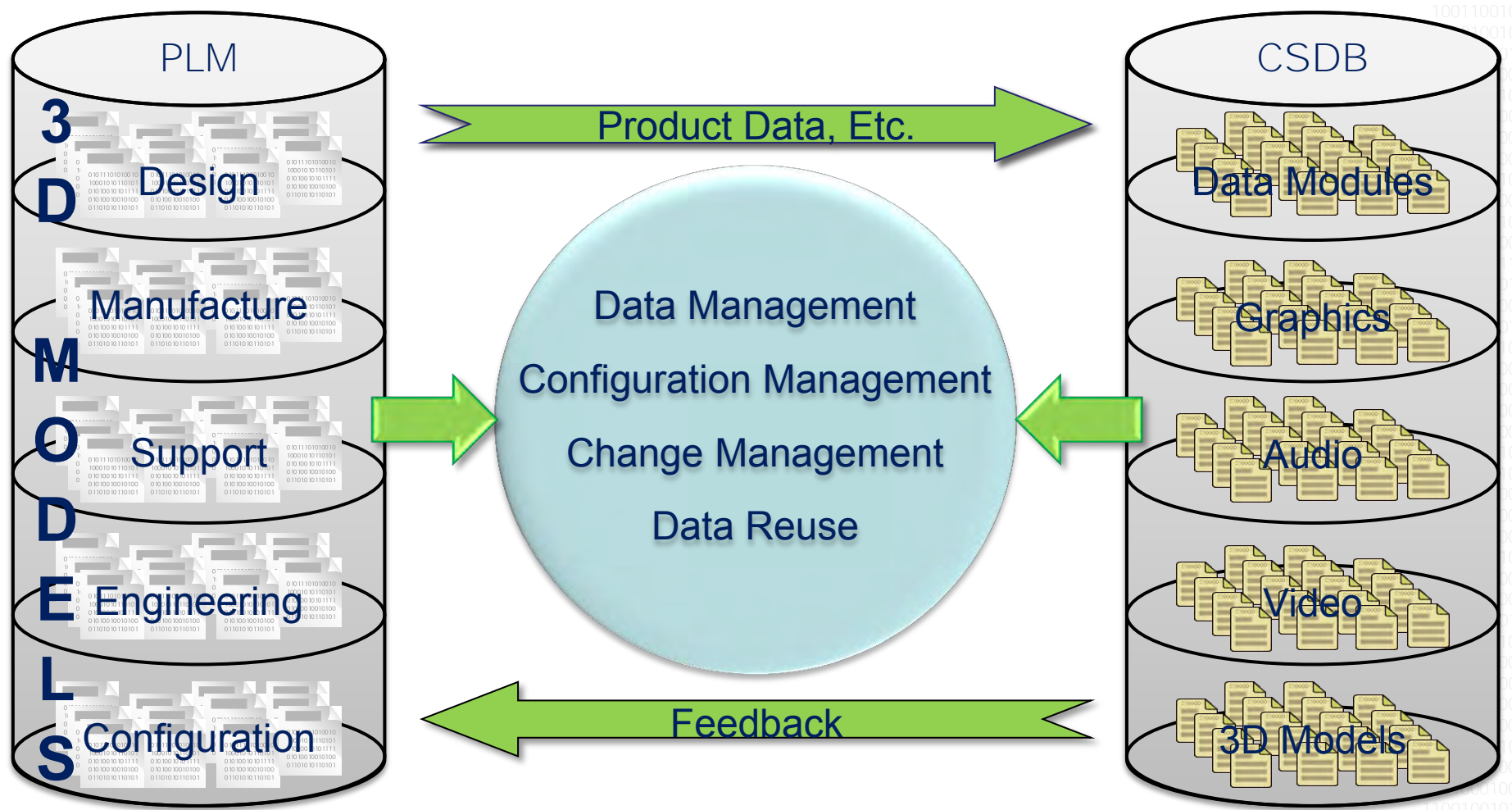



The way forward?



Need to agree
a fit for purpose
lightweight 3D
format?

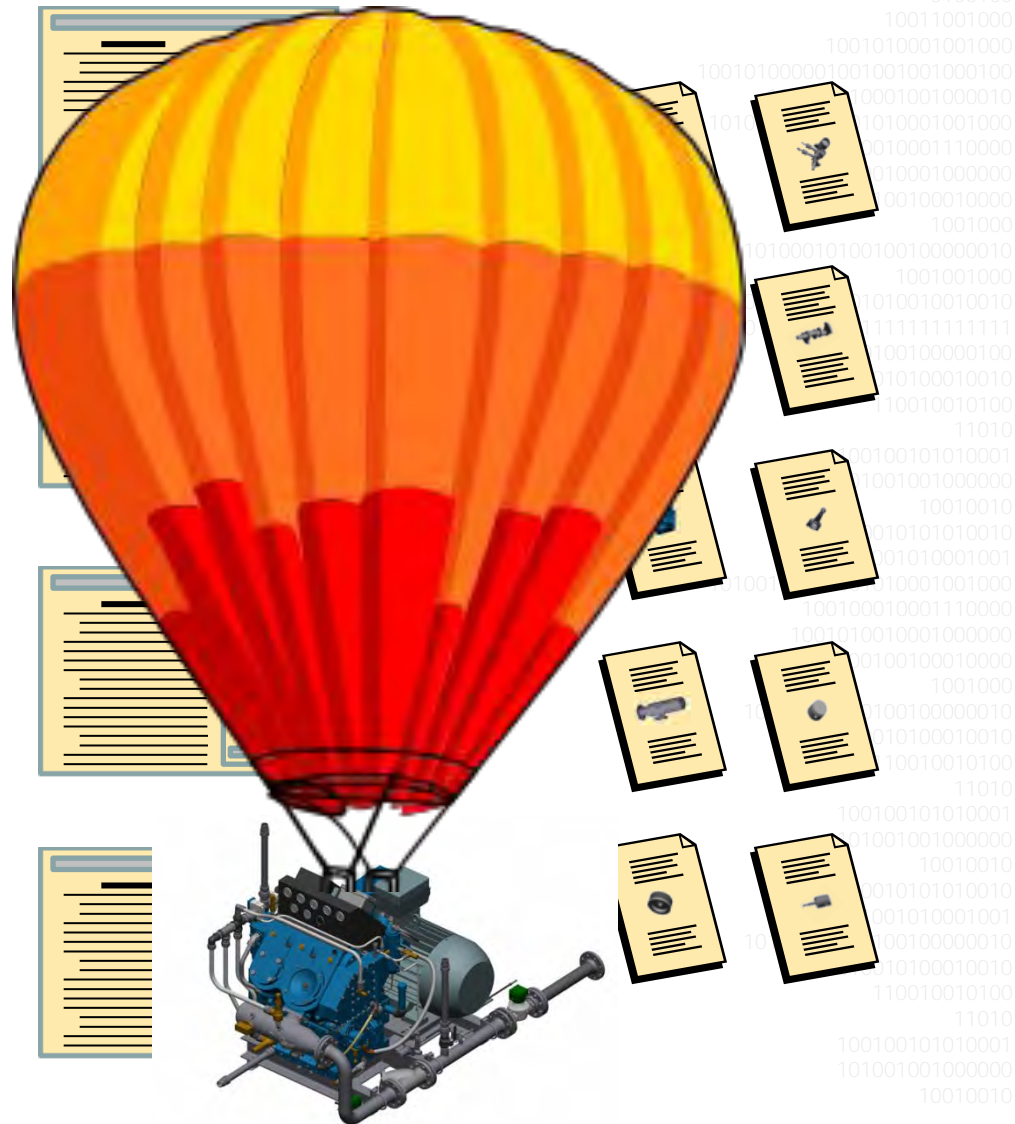

Multimedia in S1000D – The Future?

Multimedia – A solution for 3D?

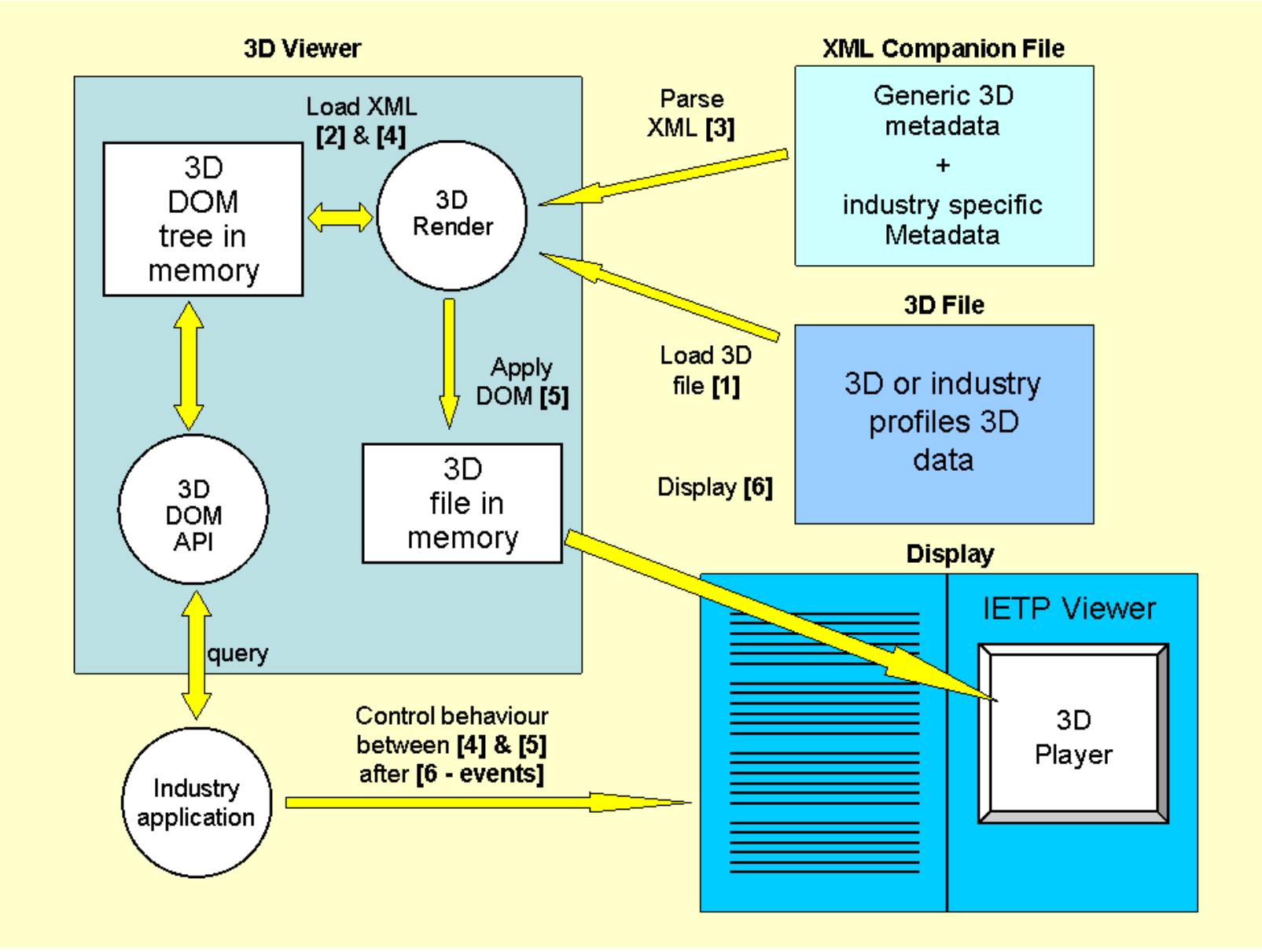

0100100
100110010
0101000100100
01001001000100
10001001000010
01010001001000
00010001110000
10010001000000
00100100010000
10010000
00100100000010
1001001000
01010010010010
01111111111111
00100100000100
10010100010010
110010010100
11010
00100101010001
01001001000000
10010010
10010101010010
1001010001001
01010001001000
00010001110000
10010001000000
00100100010000
1001000
00100100000010
10010100001000
110010010100
11010
00100101010001
01001001000000
10010010
10010101010010
1001010001001
00100100000010
10010100010010
110010010100
11010
00100101010001
01001001000000
10010010

Multimedia – 3D model use

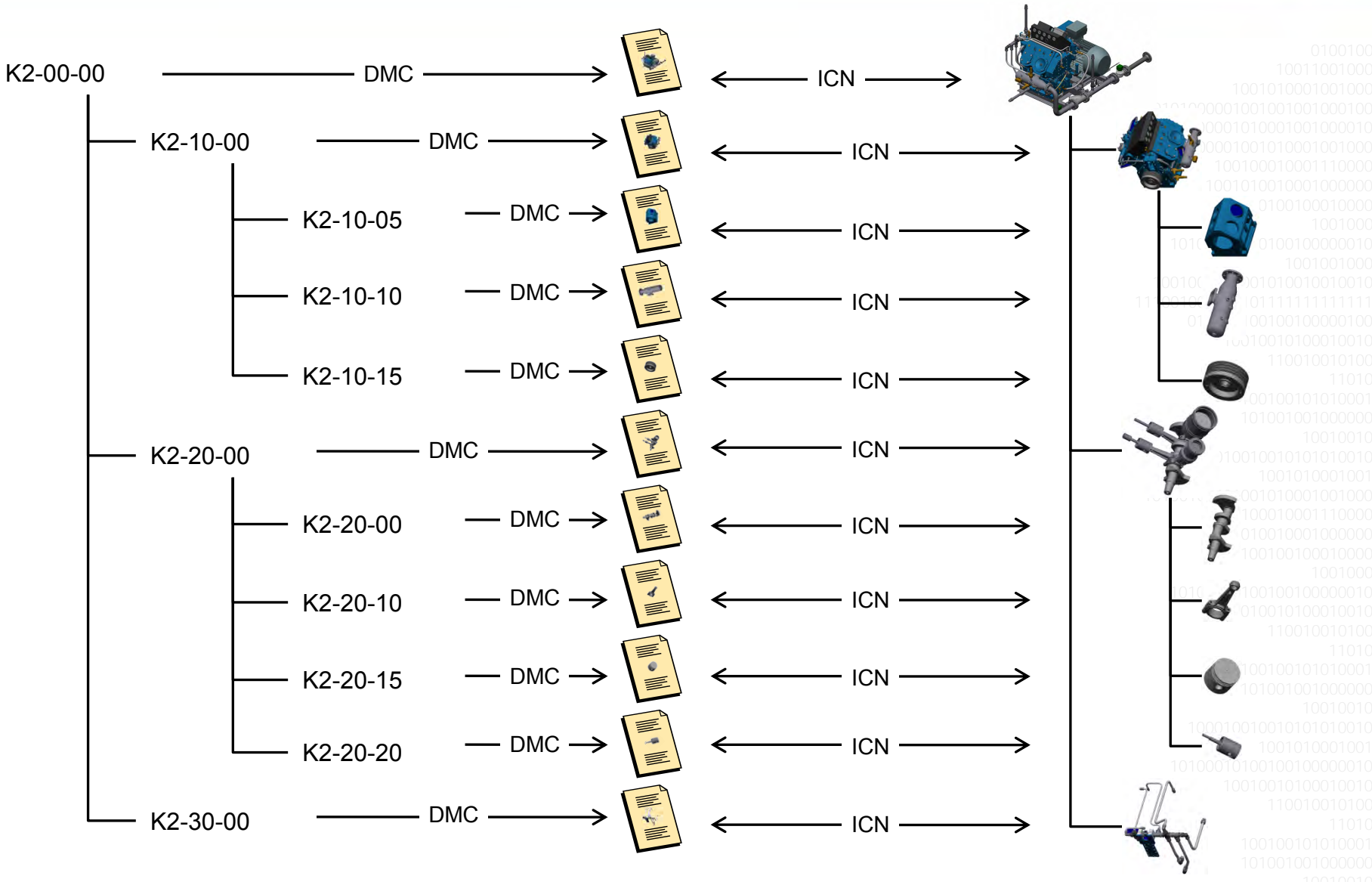

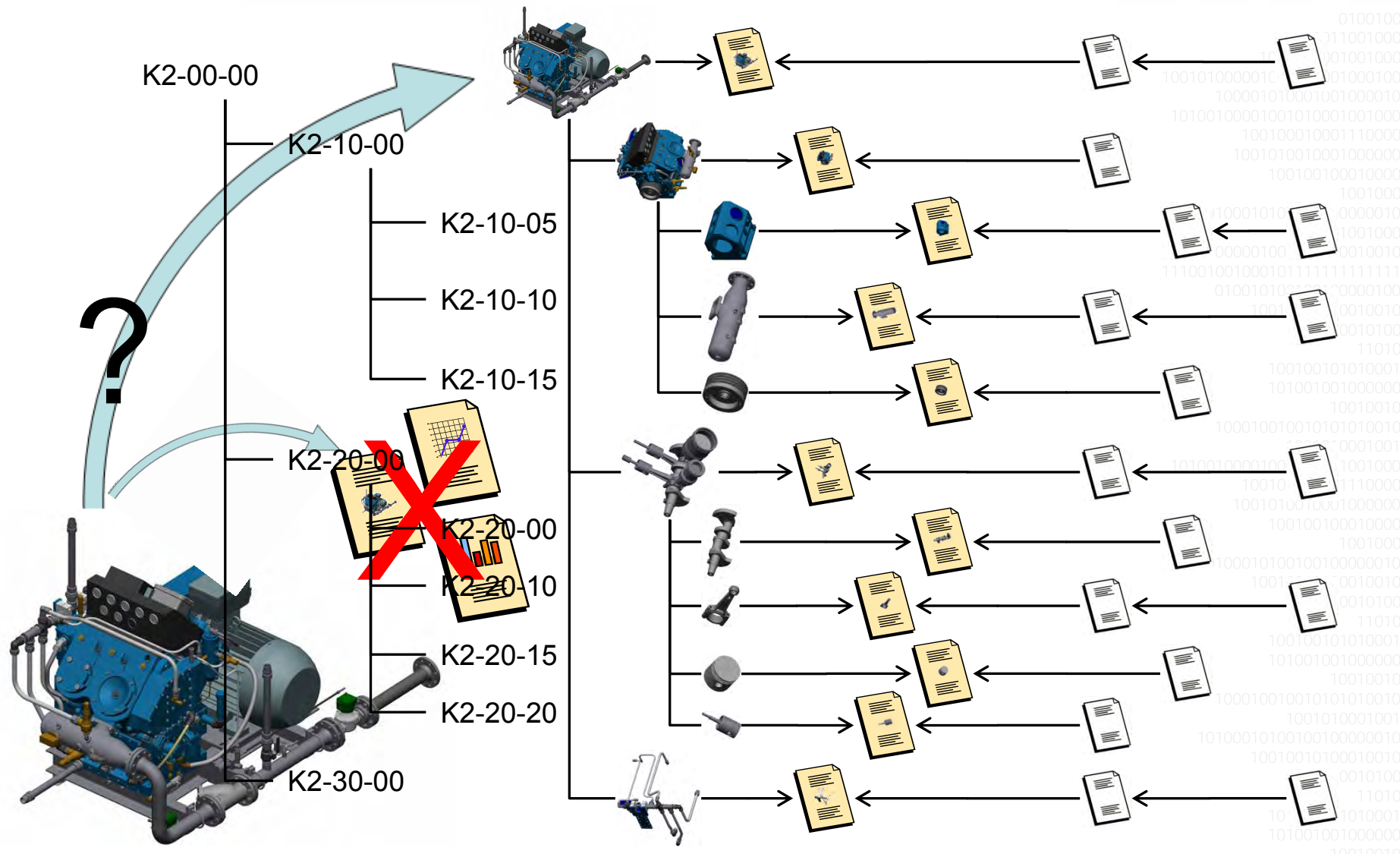

Multimedia in S1000D – The Future?

Multimedia – A solution for 3D?

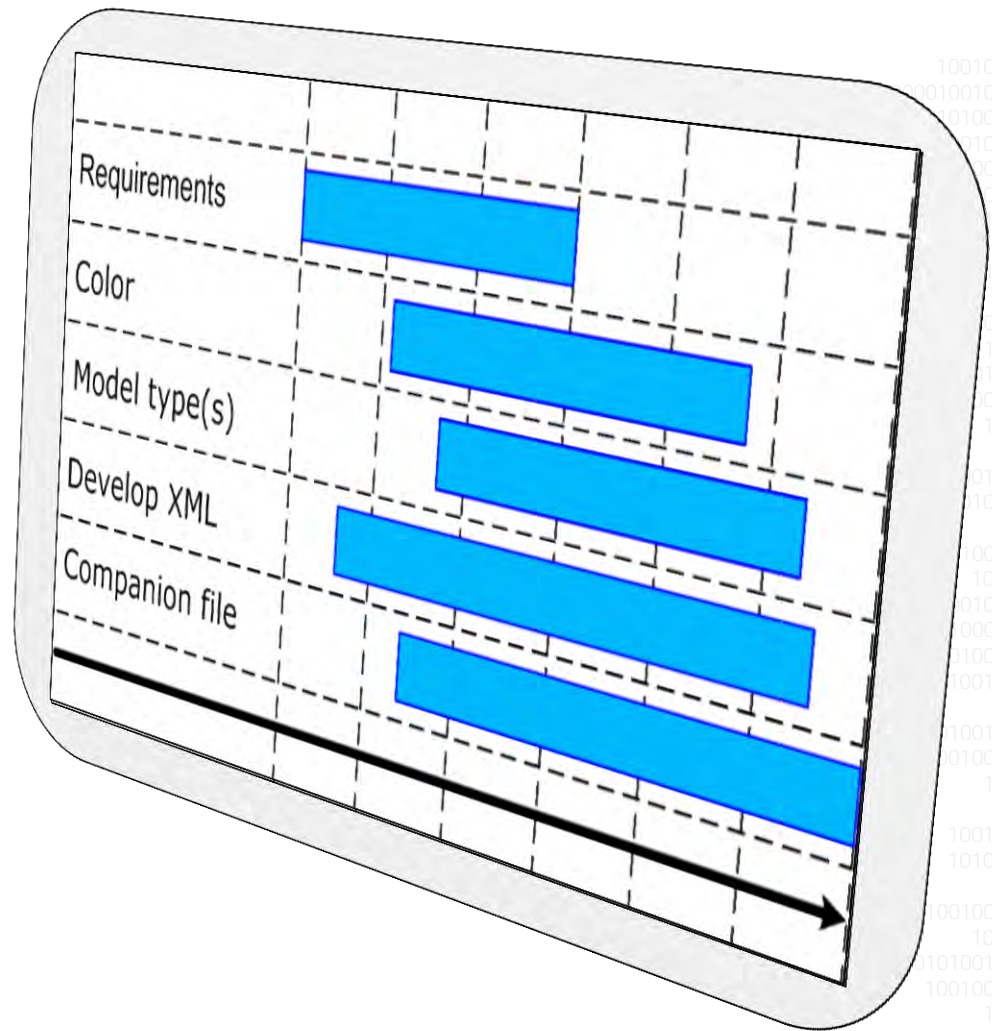

0100100
100110010
100101000100100
001001001001000100
010001001000010
1010001001000
010001110000
1001000
1001000
010010010010
1001001000
1111111111111
100100000100
010100010010
110010010100
11010
0100101010001
1001001000000
10010010
0010101010010
1001010001001
01010001001000
00010001110000
010010001000000
001001000100000
1001000
100100100000010
01001010001000
110010010100
11010
100100101010001
101001001000000
10010010
0010010101010010
1001010001001
10100100100000010
10010010100010010
110010010100
11010
100100101010001
101001001000000
10010010

- Protecting Intellectual Property
- The CAD Model as the “Single Source of Truth”
- Updating the Model
- Configuration Management
- Through Life Management

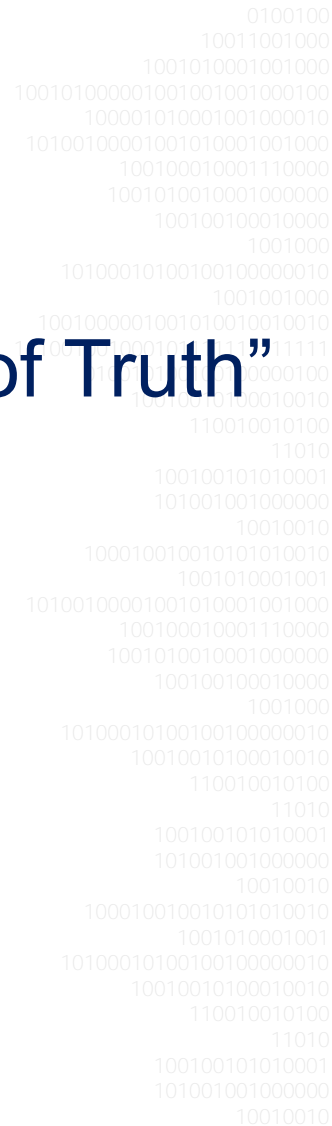

Questions

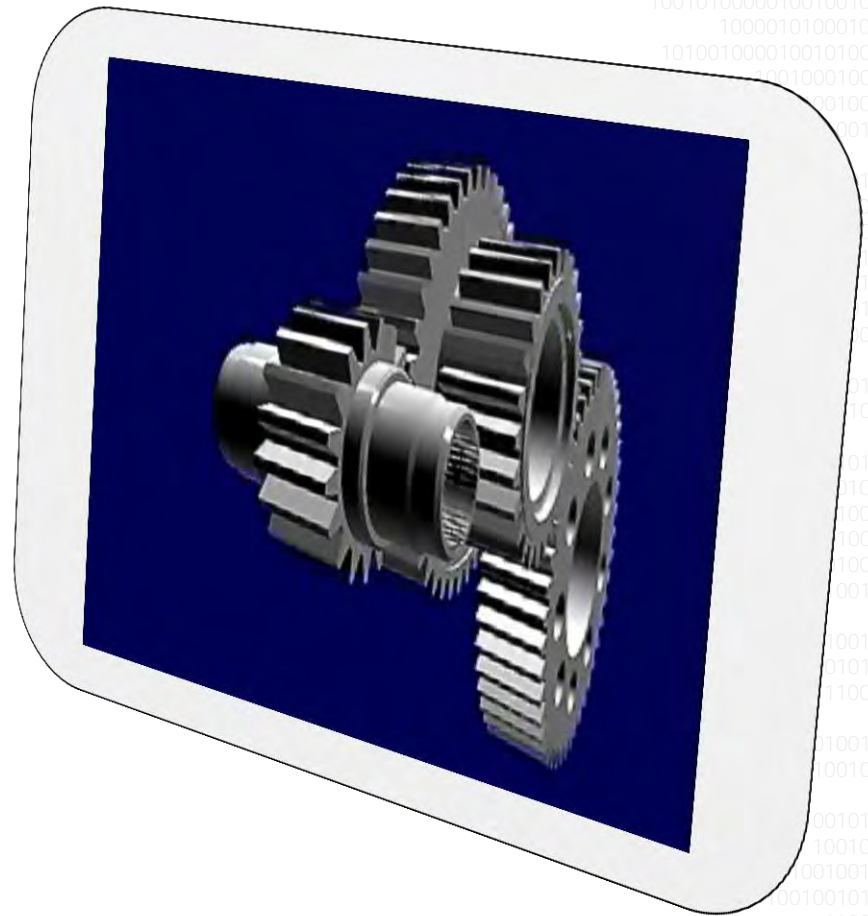

0100100
100110010
10010100001001001
100101000001001001000100
100001010001001000010
10100100001001010001001000
1001000100001110000
10010001000000
100100010000
10010000
100000010
101001000
10010010
11111111
100000100
100010010
1010010100
11010
101010001
1001000000
10010010
10100001001
0001001000
0001110000
0001000000
10100010000
1001000
100100000010
101000010010
110010010100
11010
100101010001
1001001000000
10010010
0010101010010
1001010001001
100100100000010
1001001000010010
110010010100
11010
1001001010001
101001001000000
1001001001000000
10010010